

CSB-40/ CSB-40E

COMPACT SUMMING JUNCTION BOX

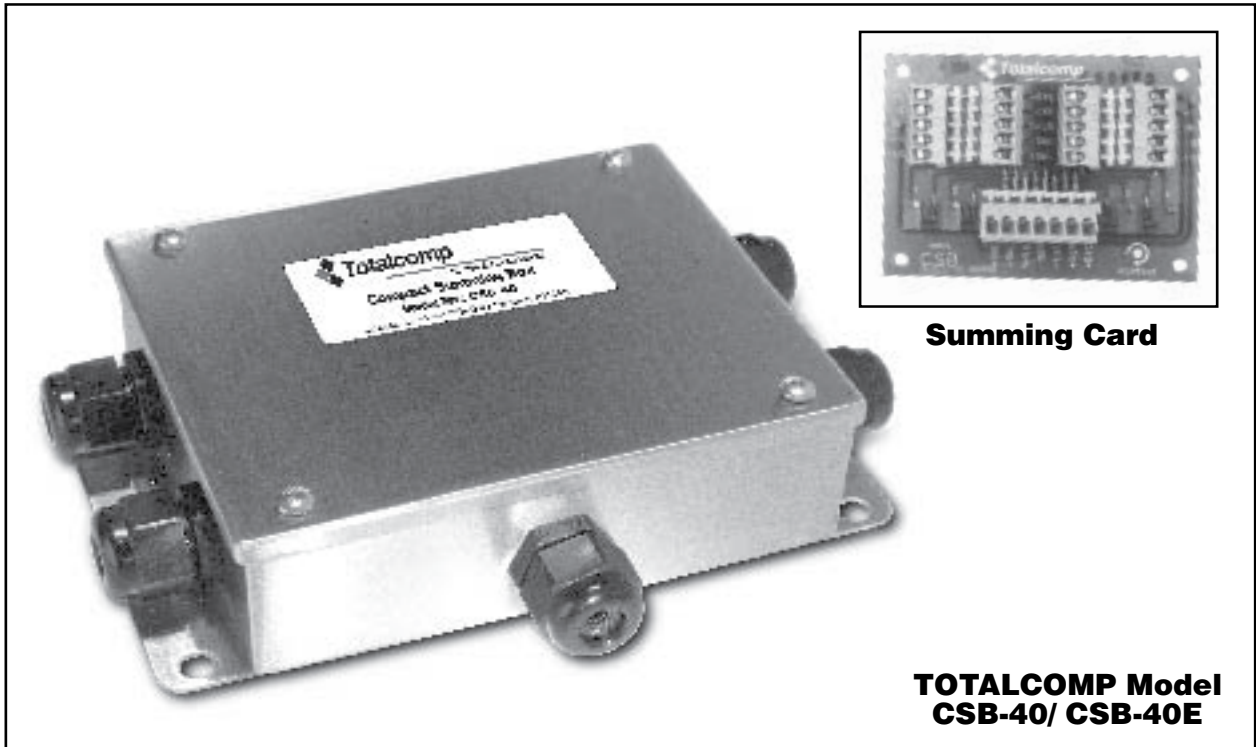

Extremely Small Size and Quick Hook-Up!

- ✓ **Signal or excitation trim for four load cells.**
- ✓ **Lever-type terminal blocks.**
- ✓ **Accepts wire size 26 to 14 AWG solid or stranded.**
- ✓ **Five nylon strain reliefs included.**
- ✓ **Corrosion resistant design.**
- ✓ **Stainless steel NEMA 4X box.**
- ✓ **Good replacement for low profile floor scales — Can fit directly under platform!**



Totalcomp[®] Scales & Components

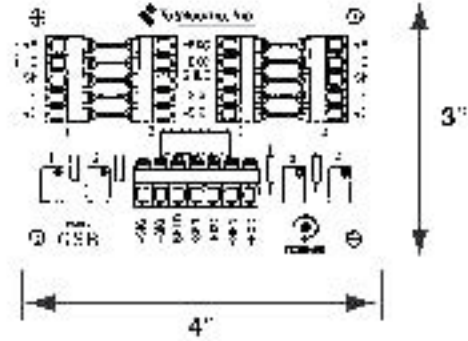
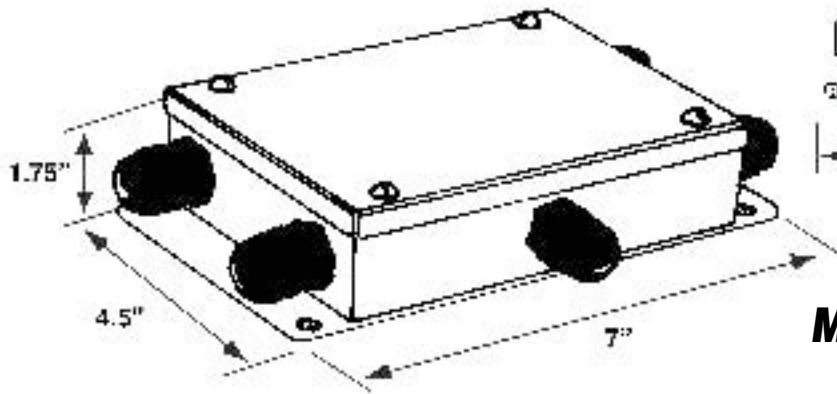

Model CSB-40/CSB-40E

COMPACT SUMMING JUNCTION BOX

CIRCUIT DESCRIPTIONS

Signal trim circuit will adjust the output of the load cell with a potentiometer and resistor shunted across the output of each load cell. Each load cell is isolated from the other load cells with 1,000 ohm series resistors in the signal lines. These isolation resistors stop the adjustments on one load cell from affecting the other load cells.

Excitation trim has one potentiometer per load cell in the excitation circuit for adjusting the load cell input voltage.

SIZE

CSB-40 - 7"W x 4.5"L x 1.75"H - 2lbs.
CSB card only - 4"W x 3"L x .75"H - 0.3lbs.
The CSB-40 has a compact size enabling it to be used under most platform scales and other space limited areas.

STRAIN RELIEFS

Five, corrosion resistant, nylon strain reliefs protect the load cell cable and instrument cable from being pulled from the terminals.

TERMINALS

Lever type make connections simple and reliable. The wire must be stripped either tinned or plain. To make connection depress the lever, insert the wire and release the lever. Accepts from 26 to 14 AWG solid or stranded wire.

ENCLOSURE

NEMA 4 stainless steel, rust proof, non-corrosive and suitable for use in the harshest environments.

TOTALCOMP LIMITED WARRANTY

Totalcomp warrants this product to be free of defects in materials and/or workmanship and suitable for the purpose(s) intended as outlined on this sheet. This warranty is effective and shall cover the purchaser for one year from the date of shipment from our plant. If this product is found to be defective by our inspection in accordance with the above listed criteria, we will replace or repair it at our expense. For warranty service, please obtain a return authorization number from us and return the item, shipping prepaid, with a written description of the problem. We will respond promptly with the results of our evaluation.